



Borough of Chambersburg

*A full service municipality in Franklin County
celebrating over 65 years of consumer owned natural gas service
over 100 years of community electric and a
regional wastewater, water, and municipal solid waste utility*

CURB AND SIDEWALK PERMIT APPLICATION

This application helps citizens of the Borough of Chambersburg understand and follow the rules outlined in the Code of the Borough of Chambersburg, Chapter 254, Article V for curb, sidewalk, and driveway entrances. Please complete the application and return it either by drop-off or mail to Borough Hall, Second Floor, 100 South Second Street, or email it to Amber Kelly at akelly@chambersburgpa.gov.

Person Performing the Work (contractor, homeowner, etc.) Name, Address, & Phone Number: _____

Contact Person's Name: _____

Is this a duplex?

Contact Person's Telephone Number: _____

Yes No

Address of Work Location: _____

Property Owner's Name (Leave blank if same as Contact Person's Name): _____

PA One Call Serial Number (Must be performed by the person performing the work per PA Law): _____

Lengths of portion(s) being replaced (ft):

Curb: _____ Driveway Entrance: _____ Drain under sidewalk: _____ Ramps: _____ Width of Roadway Cut: _____
(Only applicable if curb is being replaced)

FEES:

The purpose of the fees is to help compensate the Borough of Chambersburg for the field inspection, processing of curbs and sidewalks permits, and any required site visits. State Route's fee is slightly higher due to the correspondence with PennDOT.

Accepted Forms of Payment: Cash, Check, or Money Order (Payments may be mailed in with the permit)

Borough Street = \$45

State Route = \$75

Other fees will be collected to cover Borough costs associated with permanent restoration for excavation work associated with curb repair or construction on a Borough Street or State Route. A fee will not be collected for permanent restoration if the street where the excavation takes place is scheduled for reconstruction or overlay within 12 months of the date of the excavation permit.

IMPORTANT INFORMATION:

The person performing the work must follow the Borough of Chambersburg's current specifications for Curbs and Sidewalks. The Borough Engineer may be contacted with questions regarding the specifications. Any installation of driveway aprons or ramps will require a site visit from the Borough Engineer, who will specify which "Type" of apron to use. All driveway aprons and ramps will adhere to PennDOT RC-67M. Depressed curbs for driveways will conform to PennDOT RC-64M. The work area must always be marked with the appropriate warning devices, as referenced in PennDOT Publication No. 213, entitled "Temporary Traffic Control Guidelines".

The person performing the work must contact the Pennsylvania One Call System, Inc. at 811 or 1-800-242-1776 no less than 3 nor more than 10 business days before digging anywhere in the Commonwealth, including excavation on a Borough Street or State Route.

The person performing the work is required to secure approval from the Borough Engineer via email at bfogal@chambersburgpa.gov or via phone at (717) 251-2415 prior to the pouring of any concrete.

Permits are valid for 6 months from the approval date. Once the permit expires, a new one must be submitted.

Approval Date _____ Expiration Date _____

T:\Engineering\Permits\Curb and Sidewalk Permits\Template\CAD\Curb and Sidewalk.dwg Tuesday, May 27, 2025 10:36:52 AM

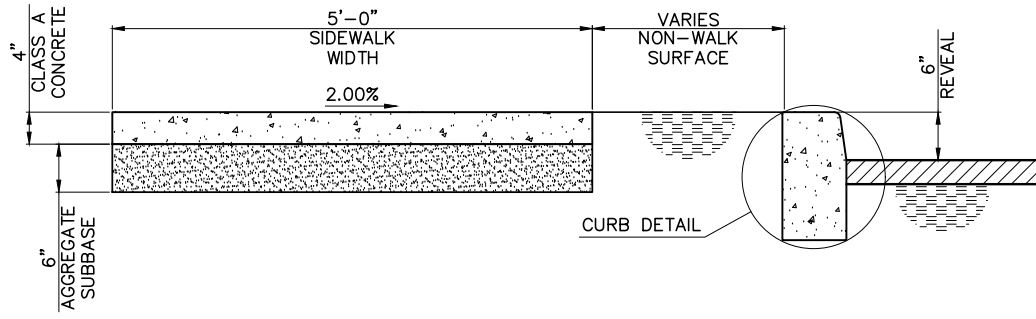

SIDEWALK TYPICAL SECTION

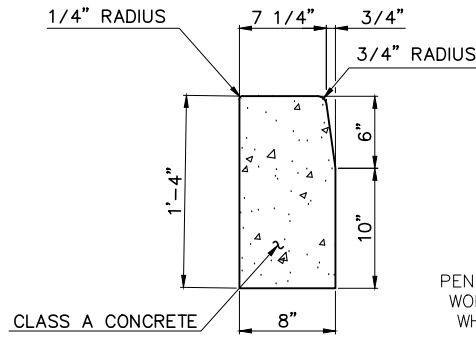

CURB DETAIL



PENNSYLVANIA ACT 199 (2004) REQUIRES 3 WORKING DAYS NOTICE FROM EXCAVATORS WHO ARE ABOUT TO DIG, BLAST, AUGER, BORE, GRADE, TRENCH OR DEMOLISH ANYWHERE IN THE COMMONWEALTH. CONTRACTOR SHALL PLACE A ONE-CALL (1-800-242-1776) PRIOR TO CONSTRUCTION.

EXPANSION JOINT NOTE:
PLACE 3/4" PREMOLDED EXPANSION JOINT MATERIAL AT ALL TIE IN AREAS.

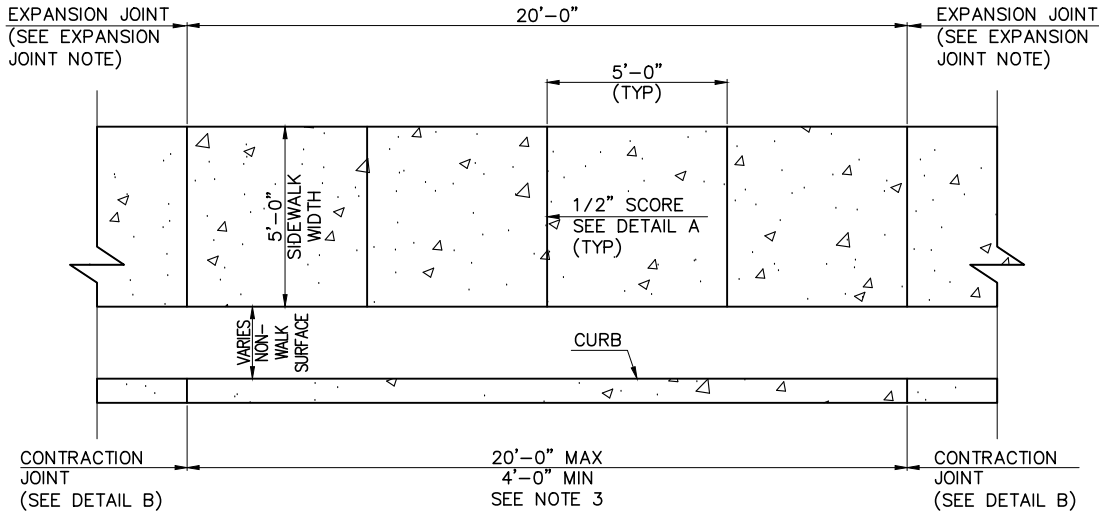

SIDEWALK PLAN

NOTES:

1. A PA ONE CALL MUST BE PERFORMED BY THE PERSON PERFORMING THE WORK PRIOR TO ANY CONSTRUCTION.
2. ALL SIDEWALKS MUST RECEIVE APPROVAL BY BOROUGH ENGINEER PRIOR TO CONCRETE POUR. THE BOROUGH ENGINEER HAS THE ABILITY TO RELEASE A STOP ORDER PER ARTICLE § 254-35 OF THE CHAMBERSBURG BOROUGH CODE.
3. ALL CONCRETE MUST BE CLASS A OR HIGHER.
4. SPACE CONSTRUCTION JOINTS IN UNIFORM LENGTHS OR SECTIONS.
5. PLACE 3/4" THICK PREMOLDED EXPANSION JOINT FILLER MATERIAL AT STRUCTURES AND AT THE END OF THE WORK DAY. CUT MATERIAL TO CONFORM TO AREA ADJACENT TO CURB OR TO CONFORM TO CROSS SECTION AREA CURB.
6. SEAL JOINTS WITH AN APPROVED SEALING MATERIAL
7. PROVIDE SLIP RESISTANT TEXTURE ON CURB RAMP BY COARSE BROOMING TRANSVERSE TO THE SLOPE OF THE SIDEWALK.
8. ALL SIDEWALKS MUST BE SEALED PRIOR TO OPENING TO PUBLIC.
9. ALL DRIVEWAY DETAILS MUST FOLLOW PENNDOT RC-67M. WITH THE TYPE BEING DECIDED BY BOROUGH ENGINEER. DEPRESSED CURBS FOR DRIVEWAYS WILL CONFORM TO PENNDOT RC-64M.

Mark	Description	By	Chk'd.	Recm'd.	Date
REVISIONS					

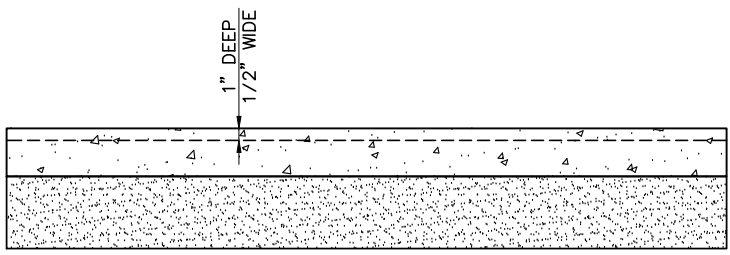

DETAIL A

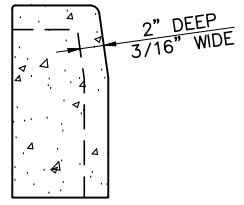

DETAIL B

BOROUGH OF CHAMBERSBURG
DEPARTMENT OF PUBLIC WORKS

CURB AND SIDEWALK

RECOMMENDED MAY 27, 2025

Shawn M. Conroy
PUBLIC WORKS DEPARTMENT HEAD

SHEET 1 OF 2

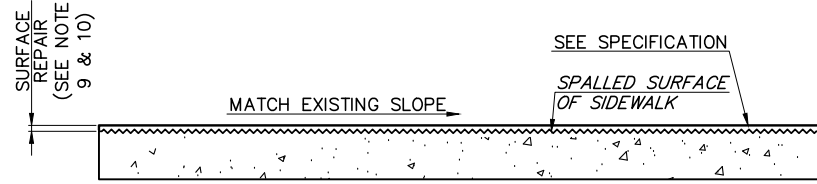

**SIDEWALK RESURFACING
TYPICAL SECTION**

SPECIFICATIONS:
TWO-COMPONENT STRUCTURAL
REPAIR MORTAR AND OVERLAY
f'c 28 DAYS = 3,000 PSI (MIN)

ONE - CALL SYSTEM



PENNSYLVANIA ACT 199 (2004) REQUIRES 3 WORKING DAYS NOTICE FROM EXCAVATORS WHO ARE ABOUT TO DIG, BLAST, AUGER, BORE, GRADE, TRENCH OR DEMOLISH ANYWHERE IN THE COMMONWEALTH. CONTRACTOR SHALL PLACE A ONE-CALL (1-800-242-1776) PRIOR TO CONSTRUCTION.

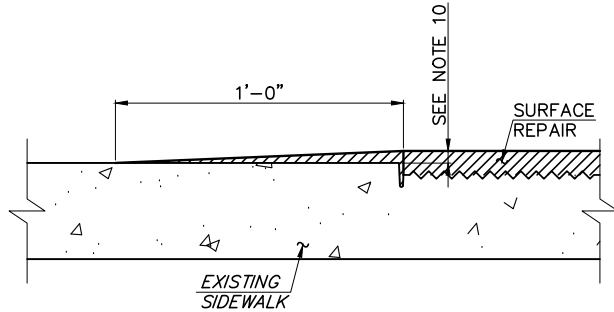

**SIDEWALK RESURFACING
RAMP DETAIL**

NOTES:

1. A PA ONE CALL MUST BE PERFORMED FROM THE PERSON PERFORMING THE WORK PRIOR TO ANY CONSTRUCTION.
2. ALL SIDEWALKS MUST RECEIVE APPROVAL BY BOROUGH ENGINEER PRIOR TO CONCRETE POUR. THE BOROUGH ENGINEER HAS THE ABILITY TO RELEASE A STOP ORDER PER ARTICLE § 254-35 OF THE BOROUGH OF CHAMBERSBURG CODE.
3. ALTERNATIVE CURBS ARE ONLY PERMITTED IN AREAS WITH MATCHING CURBS.
4. A SURFACE REPAIR CAN ONLY BE PERFORMED WITH APPROVAL FROM THE BOROUGH ENGINEER.
5. SPACE CONSTRUCTION JOINTS IN UNIFORM LENGTHS OR SECTIONS.
6. PLACE 3/4" THICK PREMOLDED EXPANSION JOINT FILLER MATERIAL AT STRUCTURES AND AT THE END OF THE WORK DAY. CUT MATERIAL TO CONFORM TO AREA ADJACENT TO CURB OR TO CONFORM TO CROSS SECTION AREA CURB.
7. SEAL JOINTS WITH AN APPROVED SEALING MATERIAL
8. PROVIDE SLIP RESISTANT TEXTURE ON CURB RAMP BY COARSE BROOMING TRANSVERSE TO THE SLOPE OF THE SIDEWALK.
9. ALL SIDEWALKS MUST BE SEALED PRIOR TO OPENING TO PUBLIC
10. MINIMUM THICKNESS IS BASED OFF MANUFACTURES SPECIFICATIONS. THE SURFACE REPAIR MUST BE LEVEL TO OR GREATER THAN THE EXISTING SIDEWALK DEPENDING ON MINIMUM THICKNESS.
11. GAP BETWEEN SIDEWALK PANELS SHALL NOT EXCEED 1/4". IF A SIDEWALK IS BEING RESURFACED A RAMP MUST BE INCLUDED IF THE GAP EXCEEDS 1/4".

EXPANSION JOINT NOTE:
PLACE 3/4" PREMOLDED
EXPANSION JOINT MATERIAL
AT ALL TIE IN AREAS.

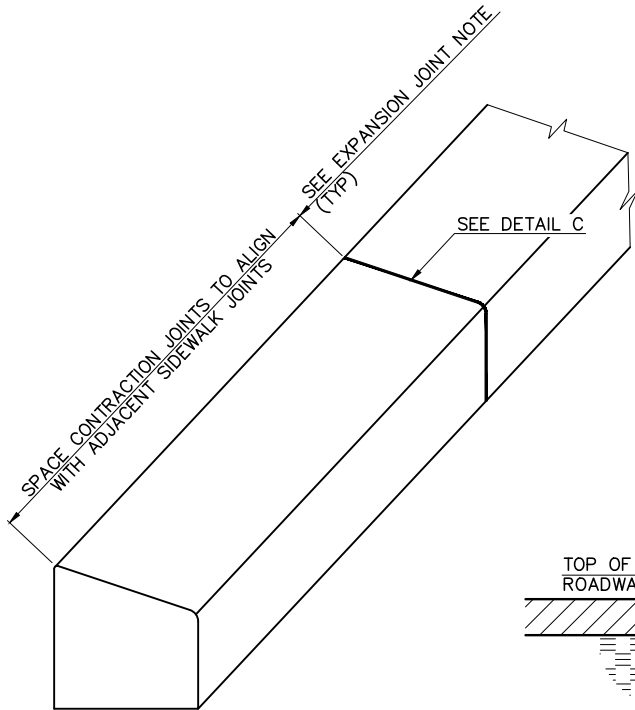

ALTERNATE CURB JOINT SPACING

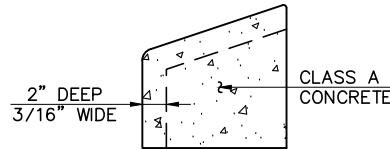

DETAIL C

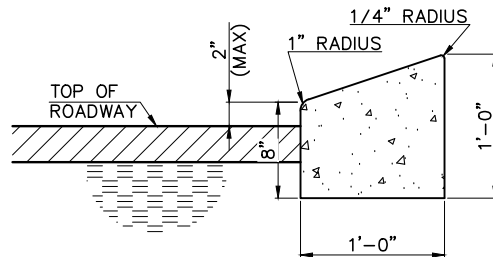

ALTERNATE CURB TYPICAL SECTION

Mark	Description	By	Chk'd.	Recm'd.	Date
REVISIONS					

BOROUGH OF CHAMBERSBURG
DEPARTMENT OF PUBLIC WORKS

ALTERNATIVE CURB
AND SIDEWALK RESURFACING

RECOMMENDED MAY 27, 2025

Shawn M. Conroy
PUBLIC WORKS DEPARTMENT HEAD

SHEET 2 OF 2